

A 170 Volt Tantalum Hybrid™ Capacitor - Engineering Considerations

David A. Evans

Evans Capacitor Company
33 Eastern Avenue
East Providence, RI 02914

ABSTRACT

The electrical performance of Hybrid capacitors (US Patent 5,369,547) using high capacitance density electrochemical capacitor cathodes, electrolytic capacitor anodes and dielectric, and compatible electrolytes is strongly influenced by the nature of the electrolyte employed and the physical characteristics of the electrodes. Management of overall capacitor performance usually involves optimizing one set of material properties against another. This work describes our efforts in producing a tantalum Hybrid capacitor with a 170 V working voltage.

INTRODUCTION

The Evans Hybrid capacitor combines the best features of both electrochemical and electrolytic capacitors by using an electrochemical capacitor cathode and an electrolytic capacitor anode. Order-of-magnitude increases in volumetric energy density over aluminum electrolytic capacitors have been reported.¹ Employing a dielectric coated anode electrode, the single-cell Hybrid capacitor is able to withstand high breakdown voltages. In contrast to electrochemical capacitors, where cell voltage is limited to the breakdown voltage of the electrolyte, the Hybrid capacitor cell voltage depends on the breakdown voltage of the anode dielectric. Units with >100 working volts/cell are now in use.

Hybrid capacitors with porous sintered tantalum anode electrode(s), RuO₂ on tantalum foil cathode electrode(s) and acid electrolyte were used in this work. These single-cell devices were sealed in conventional hermetic tantalum cases. A schematic drawing of the internal construction of these capacitors is shown in Figure 1. Figure 2. is a photograph of a one-anode element tantalum-cased tantalum Hybrid capacitor. The physical dimensions of this unit are 1.40 inch diameter by 0.2 inch high. The parts of a disassembled unit are shown in the photograph in Figure 3.

The difficulty building reliable high voltage electrochemical capacitors lies in the required use of series-connected cells, because the voltage of an electrochemical capacitor cell is limited to the breakdown potential of the electrolyte, usually <1 volt for aqueous electrolytes. If the

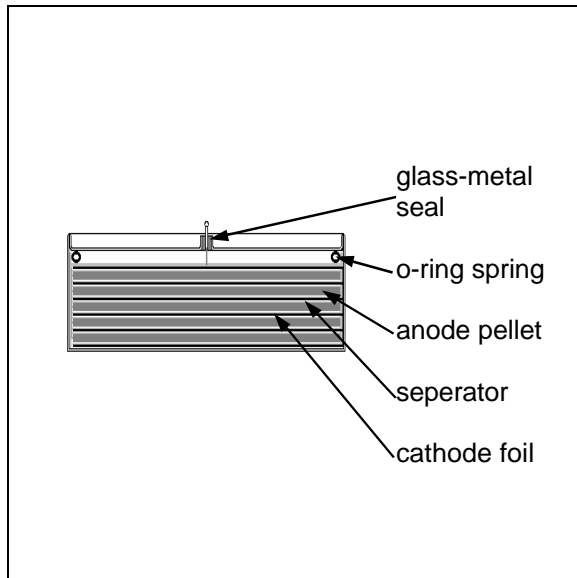

Figure 1. Schematic view showing internal construction of a multiple-anode element tantalum Hybrid capacitor.

electrical properties of all cells are identical, then the voltage in a series stack is evenly divided. Since normal process variables preclude this condition in a production scenario, cell voltage usually does not divide evenly. The situation can be overcome by reducing the average cell voltage, increasing the number of cells in series. As the number of cells in series rises, further reductions in the average cell voltage are mandated.² The performance penalties paid include reduced capacitance, increased ESR and an increased cost.

An advantage of the Hybrid capacitor is its ability to handle very high-rate charge and discharge. These devices are now in use in pulse-discharge power supplies. In one example of this application, a Hybrid capacitor provides a 200 μ s, 150 A discharge at a repetition rate of 50 Hz. With an RC product of just 0.0001 Ω ·F, this capacitor is an efficient choice. In contrast, the RC product of most electrochemical capacitors is > 0.1.

The RC product, found by multiplying a capacitor's ESR by its capacitance is a quick way to estimate the likely performance of a device in an application. For example, if the RC product of a capacitor is 1, it is capable of *efficient* charge-discharge times on the order of 1 second or longer.

The RC product is under the direct control of the design engineer. By changing the conductivity of the electrolyte or the thickness of the electrodes, one can influence capacitor

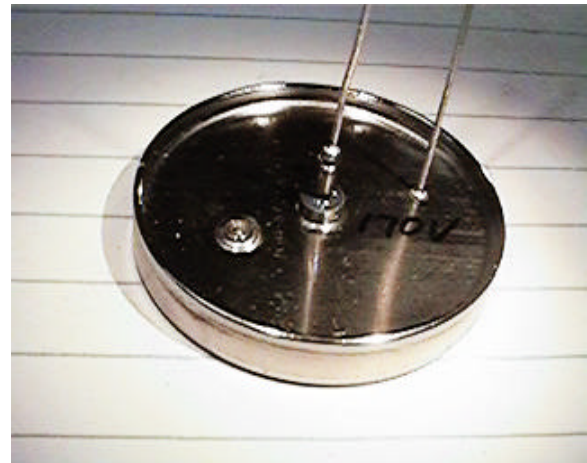

Figure 2. Photograph of the hermetic tantalum Hybrid capacitor.



Figure 3. Photograph of a dismantled tantalum Hybrid capacitor showing anode, cathode, and case elements.

properties in predictable ways. The interaction between electrolyte conductivity and anode thickness with electrical properties will now be discussed in detail.

DISCUSSION

Electrolytic capacitors (including Hybrid capacitors) are characterized by the presence of a dielectric material covering the anode electrode. In a tantalum electrolytic capacitor, the dielectric is Ta_2O_5 formed directly on the anode surface by electrochemical means. The thickness of the dielectric helps determine the breakdown voltage of the cell, and is roughly proportional to the electrochemical voltage applied during its formation. In this way, dielectric films of any desired thickness are made. Usually the dielectric film is made as thin as possible, consistent with reliable operation of the cell, providing the highest capacitance per unit of electrode. Sometimes the film is deliberately made thicker for a given working voltage, providing lower leakage current or higher operating temperature, but this is always accompanied by a reduction in capacitance.

Another aspect of Hybrid and electrolytic capacitor construction which effects the breakdown voltage of the cell is the resistivity of the working electrolyte. The breakdown voltage of the dielectric follows a semilogarithmic relationship with electrolyte resistivity, and is independent of dielectric thickness, formation voltage, electrolyte composition, or temperature.³ Figure 4, Breakdown Voltage vs. Log Resistivity shows the nature of this relationship for tantalum anodes. Similar behavior has been observed in aluminum anodes. This shows that more resistive electrolytes must be used if higher breakdown voltages are desired.

For electrolytic and electrochemical capacitors, the working voltage is a fraction of the dielectric breakdown voltage. The difference between the two provides a margin of safety for more reliable operation. For standard tantalum Hybrid capacitors, $V_b = 1.25 V_w$, where V_b is the breakdown voltage and V_w is the working voltage. For applications demanding reduced leakage current at V_w , one simply increases the ratio V_b/V_w . Once the ratio is designed, the resistivity of the electrolyte to be used can be found using the curve in Figure 4.

While using a less conductive (higher resistivity) electrolyte raises the breakdown voltage and decreases leakage current, it also increases the capacitor resistance. For this reason, it is important to choose an electrolyte with the highest allowable conductivity. It is necessary to

consider electrolyte conductivity at the maximum rated operating temperature because conductivity usually rises when electrolyte temperature is increased.

To make a 170 volt tantalum Hybrid capacitor, an electrolyte with a sufficient resistivity to give a breakdown voltage of $1.25 \times 170 = 213$ volts was needed. From Figure 4, this voltage corresponds to a resistivity about $8 \Omega\cdot\text{cm}$, or a conductivity of 125 mS. As a further requirement, the electrolyte should remain in the liquid phase over the operating temperature range of the capacitor, -60°C to 85°C . Of course, the electrolyte must also be electrochemically stable and compatible with the capacitor

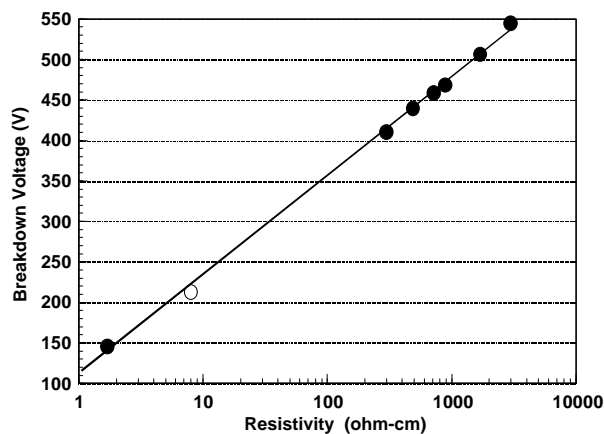

Figure 4. Breakdown voltage vs. Log electrolyte resistivity for Ta_2O_5 dielectric in various aqueous and non-aqueous electrolytes.³

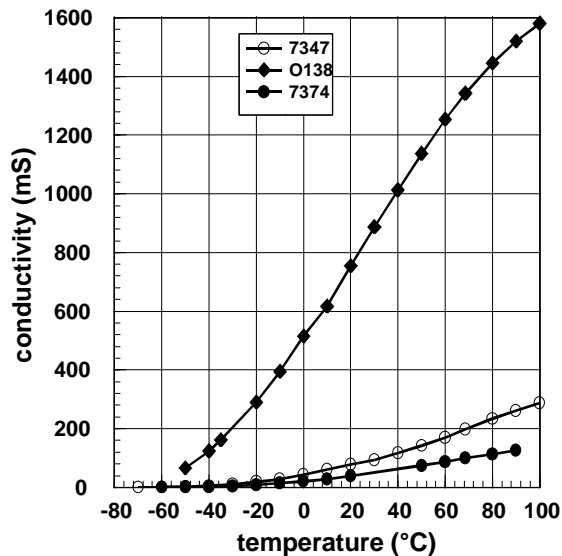

Figure 5. Conductivity vs. Temperature for various sulfuric acid based electrolytes.

electrode materials. Lastly, the electrolyte should contain sufficient H^+ ions to guarantee efficient operation of the cathode. We decided to focus on aqueous electrolytes containing sulfuric acid. Figure 5 gives the temperature dependence of conductivity for various sulfuric acid based electrolytes. Electrolyte 0138 is a 38 wt. % solution of sulfuric acid in water. This electrolyte is customarily used in wet-tantalum electrolytic capacitors and in tantalum Hybrid capacitors of up to 125 working volts. Although a rather difficult material to handle in some respects, it does have the highest conductivity of aqueous electrolytes and remains in a liquid state to below $-55^{\circ}C$. However, its conductivity is much too high for 170 V application, and reducing the acid concentration to lower the conductivity raises the freezing point to an

unacceptably high temperature.

In response, we formulated other electrolytes from 70/30 % mixtures of ethylene glycol and water, adjusting the conductivity by adding small amounts of sulfuric acid. The procedure followed was to add sulfuric acid to known amounts of 70/30 mixture at $85^{\circ}C$, monitoring conductivity until the desired level of conductivity was reached, then determining by weight the amount of sulfuric acid added. These materials display stable performance over a wide temperature range, without phase change down to a temperature of below $-60^{\circ}C$. Electrolyte 7347 has a room temperature conductivity of about 100 mS and electrolyte 7374 has a conductivity of about 120 mS at $85^{\circ}C$.

In order to determine the impact on capacitor performance of changing to an electrolyte of lower conductivity, an evaluation capacitor was constructed using electrolyte 7374. The electrodes used were taken from a standard 125 V Hybrid capacitor. The voltage was maintained at 170 V for 96 h at $85^{\circ}C$, and leakage current was monitored, but there was no evidence of breakdown. The capacitance, ESR and R·C product of this capacitor are given in Table 1. As expected, the results show a dramatic increase in resistance for the 7374 electrolyte capacitors. The R·C product provides the most satisfactory means of comparison, as it removes from consideration the differences in resistance introduced by changing the anode mass.

Table 1. The table to the right gives the room temperature capacitance and ESR of standard, 7374 electrolyte-standard electrode, and 7374 electrolyte-thin electrode single anode element Hybrid capacitors.

device description	capacitance, 120 Hz (μF)	ESR, 1 kHz (Ω)	R·C ($\Omega \cdot F$)
0138 electrolyte-standard electrode	625	0.207	1.35×10^{-4}
0138 electrolyte-thin electrode	415	0.132	5.48×10^{-5}
7374 electrolyte-standard electrode	520	0.920	4.78×10^{-4}
7374 electrolyte-thin electrode	408	0.750	3.06×10^{-4}

Decreasing the thickness of the anode electrode can lower the resistance of the capacitor, primarily because the average distance through which current must flow in the electrolyte is reduced. To gauge the effectiveness of this approach in a Hybrid capacitor, anode electrodes of two thicknesses were made. The results in standard (0138) electrolyte and 170 V (7374) electrolyte for standard thickness (0.090") and thin (0.054") are listed in Table 1. As previously discussed, R·C comparisons are the most useful because the electrodes used weighed 16 g for the 0.090" and 9.5 g for the 0.054" thick.

There are practical limits to making thinner anode electrodes. Reducing the thickness without increasing the diameter of the electrode, as was the case here, decreases the anode weight, and consequently, the capacitance. An obvious remedy would be to concurrently increase the anode diameter, keeping the volume constant. Due to the requirement of physical flatness in the finished anode pellet, the best diameter to thickness ratio we have reliably achieved on a production basis is about 35:1.

Another approach is to stack multiple elements in parallel. The Figure 6 photograph shows the typical arrangement. This strategy allows high capacitance values with low resistance, but part-count and complexity of assembly are increased.

CONCLUSION

The semilogarithmic relationship between dielectric breakdown voltage and electrolyte resistivity was successfully used to design a tantalum Hybrid capacitor with a working voltage of 170 V. The specific aqueous electrolyte designed was liquid over a wide temperature range. Increasing the electrolyte resistivity increases the device R·C product while reducing the anode electrode thickness decreases it. Units with multiple parallel connected electrodes are a practical way to reduce the R·C product of a Hybrid capacitor. This design approach allows the future construction of even higher voltage devices.



Figure 6. Photograph of a partially dismantled polypropylene case tantalum Hybrid capacitor showing stacked arrangement of anode electrodes connected in parallel. The top cathode plate and separator has been removed .

REFERENCES

1. D. A. Evans, "The Littlest Big Capacitor - an Evans Hybrid", Proceedings of The Fifth International Seminar on Double Layer Capacitors and Similar Energy Storage Devices, 12/95, Deerfield Beach, Florida.
2. J. R. Miller, "Electrochemical Capacitor Voltage Balance: Cell Uniformity Requirements for High-Voltage Devices", Proc. 36th International Power Sources Symposium, pp. 15-18, 6/94.
3. F. J. Burger and J. C. Wu, "Dielectric Breakdown in Electrolytic Capacitors", J. Electrochemical Soc.: ELECTROCHEMICAL TECHNOLOGY, pp. 2039 - 2042, December 1971.